

USER' S MANUAL

OCB-VT-008

GPS Vehicle Tracker



TABLE OF CONTENTS

1.	Copyright and Disclaimer	3
2.	Applications	3
3.	Features.....	3
4.	Hardware Installation.....	4
4.1	OCB-VT-008 and its Accessorie	4
4.2	Optional Accessories	4
4.3	Install SIM Card	4
4.4	Install Power and I/O Cable.....	5
4.5	Install Headset Phone (RS232 Interface).....	7
4.6	Install Camera (RS232 Interface).....	7
4.7	Install GPS Navigator (RS232 Interface).....	8
4.8	Install RFID Reader (Wiegand Interface)	8
4.9	Install GPS/GSM Antennas	8
4.10	Install Micro SD	9
5.	Mount the OCB-VT-008 unit	9
6.	LED Indications.....	9
7.	Unit Configuration	9

1. Copyright and Disclaimer

Information in this user guide may be changed at any time without prior notification.

This user guide nor any parts thereof may not be reproduced for any purpose whatsoever without the written consent of (NODAC), nor transmitted in any form either electronically or mechanically, including photocopying and recording.

In no event shall Meiligao (NODAC) be liable for direct, indirect, special, incidental, or consequential damages (including but not limited to economic loss, personal injury, and loss of asset and property) arising out of the use or inability or illegality to use the product or documentation.

2. Applications

- Vehicle Real Time Tracking
- Car Security/Anti-Hijack
- Fleet Management

3. Features

- SiRF III GPS and Quad Band GSM 850/900/1800/1900Mhz
- Track by SMS/GPRS (NODAC Protocol)
- Track on Demand
- Track by Time Interval
- Track by Distance Interval
- Track on Mobile Phone
- Listen-in or Two-way Audio (Optional)
- Internal Flash Memory (4M)
- Inbuilt Accelerating Sensor
- Inbuilt Motion Sensor
- Internal Backup Battery
- SOS Alarm
- Geo-fence Alarm
- GPS Blind Area Alarm
- Low Battery Alarm
- Speeding Alarm
- Impact Alarm
- Tow Alarm
- GPS Antenna Cut Alarm
- External Power Cut Alarm
- Mileage Report
- Engine Cut (Engine immobilization)
- Inbuilt Super Magnet (optional)
- Handset Phone (optional)

- Camera (optional)
- Micro SD Card Memory for Storing Pictures (Optional)
- RFID Reader (optional)
- LED Display (optional)
- LCD Display (optional)
- 3 Digital Inputs
- 3 Outputs
- 3 Analog Input Detection

4. Hardware Installation

4.1 OCB-VT-008 and its Accessories

- OCB-VT-008 Main Unit with Battery
- GPS Antenna
- GSM Antenna
- I/O Cable
- SOS Button
- USB Data Cable
- CD

4.2 Optional Accessories

- Camera
- Handset Phone
- RFID Reader
- LCD Display (Navigation, Dialing and Conversation, Message Display)

4.3 Install SIM Card

Check that the SIM has not run out of credit (test the SIM in a phone to make sure it can send and receive SMS);

Check that the SIM Lock code is turned off;

If you require the function of sending an SMS location report to the authorized phone number when it makes a call to the OCB-VT-008, please make sure the SIM installed supports displaying caller ID.

Before installing the SIM card, turn off the power for OCB-VT-008. Unscrew and remove the cover of the SIM card slot.



Insert the SIM card by sliding it into the card slot with the chip module facing down.



Put back the cover and screw it up.

4.4 Install Power and I/O Cable

The I/O cable is a 12-pin cable including power, analog inputs, positive and negative inputs, and outputs ports.



PIN Number	Color	Description
1	Red	DC In (power source). Input voltage: 9V~36V. 12V suggested
2	Black	Ground
3	White	Digital Input3. Positive triggering
4	White	Digital Input1. Negative triggering(Defaulted as SOS Panic Button)
5	White	Digital Input2. Negative triggering
6	Black	Ground
7	Yellow	Output1. Low voltage (0V) when effective and open drain when ineffective. Output open drain sink voltage (ineffective): 45V max. Output low voltage sink current (effective): 500mA max
8	Blue	12 Bits Resolution Analog Input1. 0~6V DC Detection
9	Yellow	Output2. Low voltage (0V) when effective and open drain when ineffective. Output open drain sink voltage (ineffective): 45V max. Output low voltage sink current (effective): 500mA max.
10	Blue	12 Bits Resolution Analog Input2. 0~6V DC Detection
11	Yellow	Output3. Low voltage (0V) when effective and open drain when ineffective. Output open drain sink voltage (ineffective): 45V max. Output low voltage sink current (effective): 500mA max.
12	Blue	12 Bits Resolution Analog Input3. 0~6V DC Detection

Installation/Connection Examples:

1) Power/GND

Connect GND (-Black) and Power (+Red) wires to the battery of vehicle.

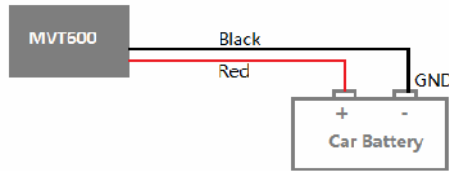

2) Digital Input (Negative Triggering)

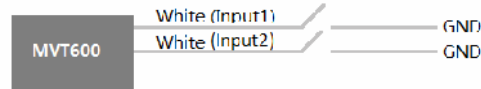

3) Digital Input (Positive Triggering)

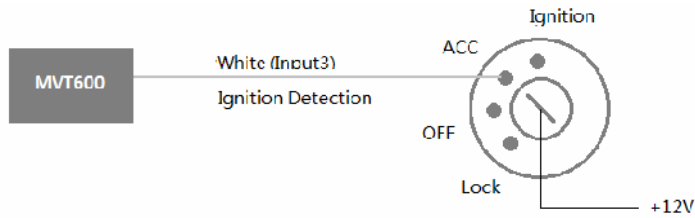

4) Output

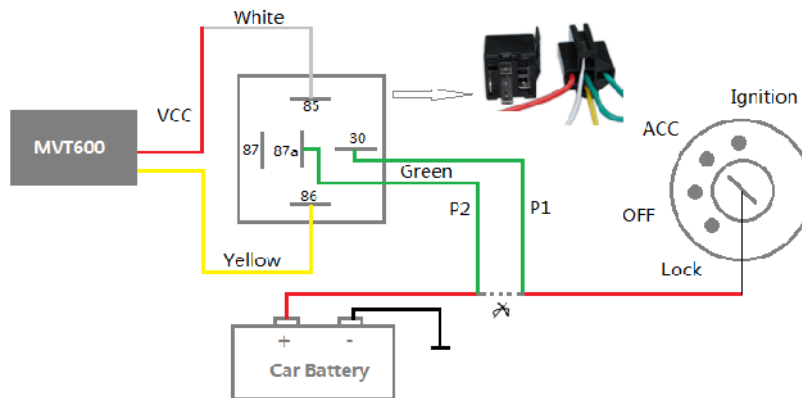

5) Analog Input

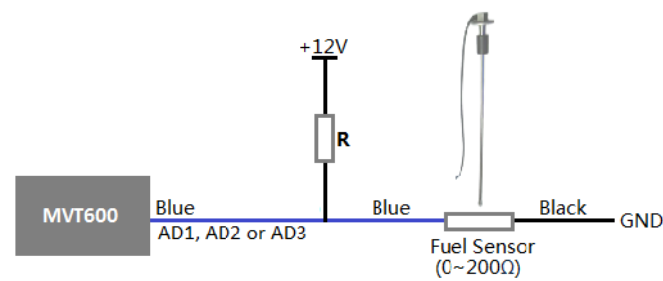

Note:

Fuel level sensors supplied by us are resistance-type sensors with output resistance: 0-2000Ω (ohm).

For the circuit shown on above figure, if VCC is 12V, R should be 200Ω (ohm) and if VCC is 24V then R should be 600Ω (ohm) to make the input range to AD1 or AD2 is 0-6V.

Below formula is for calculating the fuel percent left for this fuel level sensor:

$$\frac{\text{Value}_{AD1 \text{ or } AD2}}{1024} \times 100\%$$

The value must be converted into decimal, for example, 0x0267 is 615 in decimal.

4.5 Install Headset Phone (RS232 Interface)



PIN Number	Color	Description
1	Red	Power Output. Output Voltage: 5V
2	Black	Ground
3	White	Handset Phone RS232 TX (OCB-VT-008 RX)
4	Yellow	Handset Phone RS232 RX (OCB-VT-008 TX)
5	Orange	Microphone Positive
6	Grey	Microphone Negative
7	Purple	Speaker Positive
8	Brown	Speaker Negative

Note: This connector also supports LCD Display, Navigator, RFID reader or other external devices provided that they are RS232 interface and conform with NODAC Protocol.

4.6 Install Camera (RS232 Interface)



Camera1 RS232 Interface		
PIN Number	Color	Description
1	Red	Power Output. Output Voltage: 5V
2	Black	Ground
3	Yellow	Camera RS232 TX (OCB-VT-008 RX)
4	Green	Camera RS232 RX (OCB-VT-008 TX)

Camera2 RS232 Interface		
PIN Number	Color	Description
1	Red	Power Output. Output Voltage: 5V
2	Black	Ground
3	Yellow	Camera RS232 TX (OCB-VT-008 RX)
4	Green	Camera RS232 RX (OCB-VT-008 TX)

Note: These connectors also support LED Display provided that they are RS232 interface and conform with NODAC Protocol.

4.7 Install GPS Navigator (RS232 Interface)



RS232 Interface (GPS Date Display)		
PIN Number	Color	Description
1	Red	Power Output. Output Voltage: 5V
2	Black	Ground
3	Yellow	RS232 TX (OCB-VT-008 GPS RX)
4	Green	RS232 RX (OCB-VT-008 GPS TX)

4.8 Install RFID Reader (Wiegand Interface)



PIN Number	Color	Description
1	Red	Power Output. Output Voltage: 5V
2	Black	Ground
3	Green	RFID Data0
4	Yellow	RFID Data1

4.9 Install GPS/GSM Antennas



GPS Antenna

GSM Antenna

Connect the GSM antenna to the SMA connector which is 'GSM' text labeled. The GSM antenna is non-directional, so you can hide it in any place of vehicle.

Connect GPS antenna to the GPS connector which is 'GPS' labeled. The optimum location for the GPS antenna is on the roof of the vehicle. The covert and GPS antenna are directional, make sure they are facing up and laying as flat as possible. Secure them in place with glue or zip ties.

Note: Do not shield or cover the GPS antenna with any objects containing metal.

4.10 Install Micro SD

There's a Micro SD card slot under the On/Off button. Micro SD card can be used to store the pictures taken by the camera.



5. Mount the OCB-VT-008 unit

If mounting required, there are 4 screw holes on the OCB-VT-008, 2 along either side that act as fixing points to the vehicle.

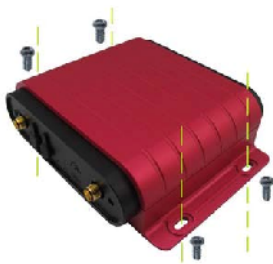

6. LED Indications



Press and hold the Power Key for 3~5 seconds to turn on/off OCB-VT-008.

GPS LED (Blue)	
On	One button is pressed or input is active.
Flashing (every 0.1 second)	Initializing
Flashing (0.1 second on and 2.9 seconds off)	OCB-VT-008 has a GPS fix
Flashing (1 second on and 2 seconds off)	OCB-VT-008 has no GPS fix
GSM LED (Green)	
On	One call is coming in / one call is being made
Flashing (every 0.1 second)	Initializing
Flashing (0.1 second on and 2.9 seconds off)	OCB-VT-008 is connected to the GSM network
Flashing (1 second on and 2 seconds off)	OCB-VT-008 is not connected to the GSM network

7. Unit Configuration

Connect the USB Data Cable between OCB-VT-008 and PC and use NODAC Parameter Editor to configure the

OCB-VT-008.



Please refer to NODAC Parameter Editor User Guide for more information regarding configuration and functions.

Please refer to NODAC SMS/GPRS Protocol for more information regarding SMS and GPRS commands.